

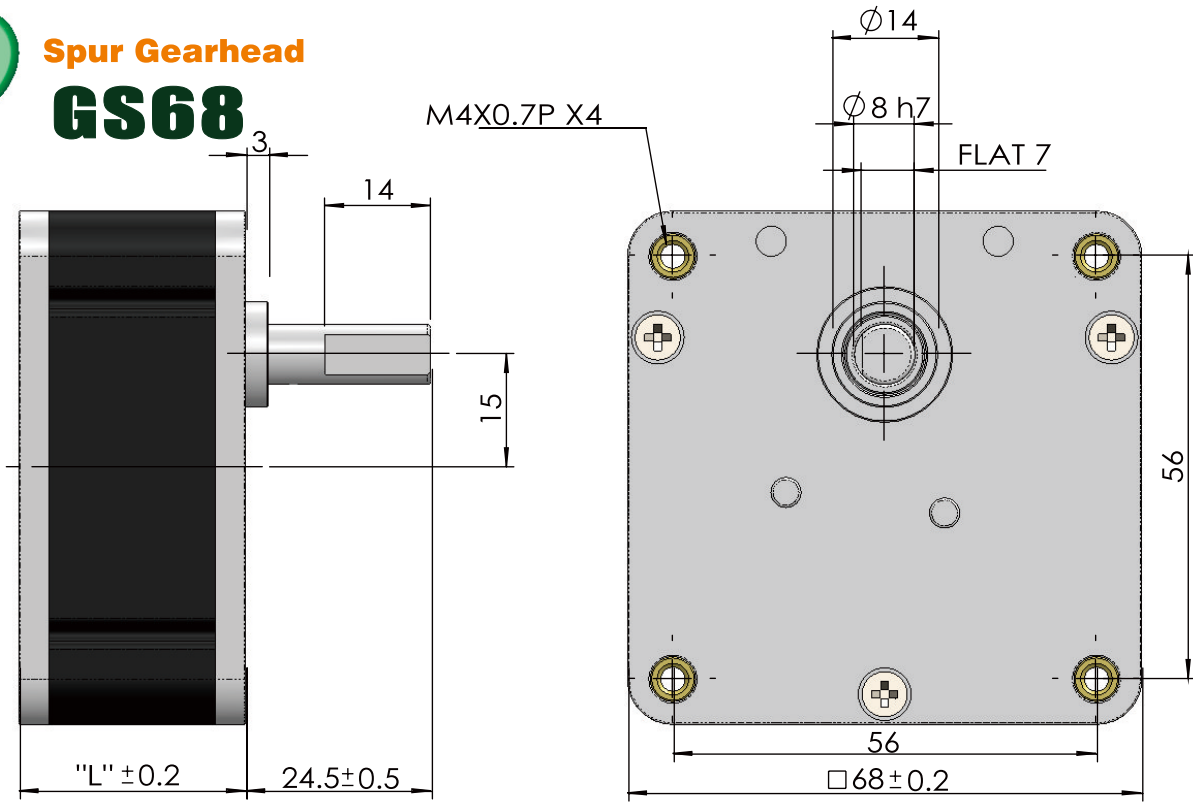

Spur Gearhead
GS68



Type	A	B	C	D	E	F	G	H	I	J	K	L	M	N	O	P	Q	R	S	T	U	V	W	X	Y	Z
Ratio	6.25	12.5	18.75	25	37.5	50	75	100	125	150	187.5	200	250	300	375	400	500	600	750	800	1000	1500	2000	2500	3000	4000
Stages	2		3			4						5					6									
Dim. "L"	22		26			30						34					38									
Eff %	81		73			65						60					53									
Cont. Torque	5 kg-cm		10 kg-cm			30 kg-cm						60 kg-cm					60 kg-cm									
Peak Torque	15 kg-cm		30 kg-cm			90 kg-cm						180 kg-cm					180 kg-cm									

Gear motor
GS68-20Y&28Y

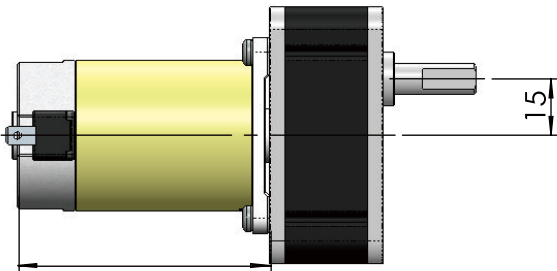

DC4060-20Y 61.5mm
DC4065-28Y 66.5mm

Gear motor
GS68-GF42 Brushless

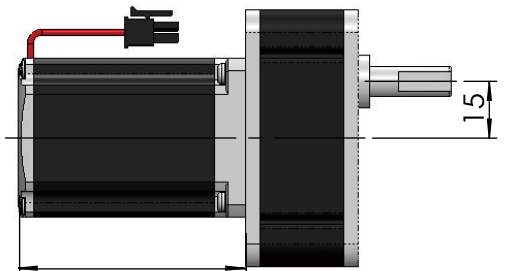

"GF42S" 45mm
"GF42M" 60mm "GF42L" 75mm

Gear motor
GS68-30Y&55Y

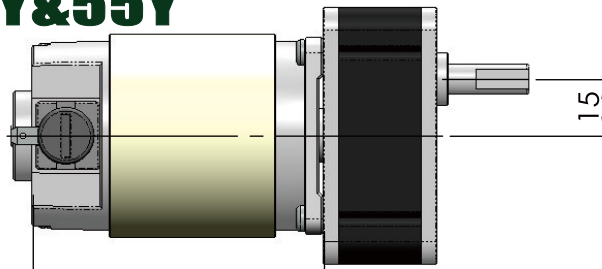

DC5475-30Y 77mm
DC54100-55Y 107mm