

Brushless
RE42

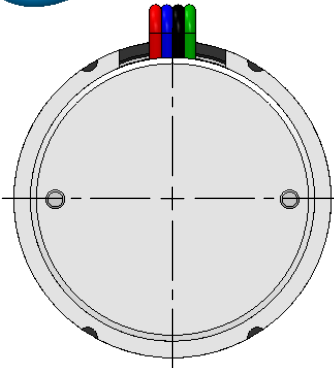

Model	"L"
42S	45
42M	60
42L	75

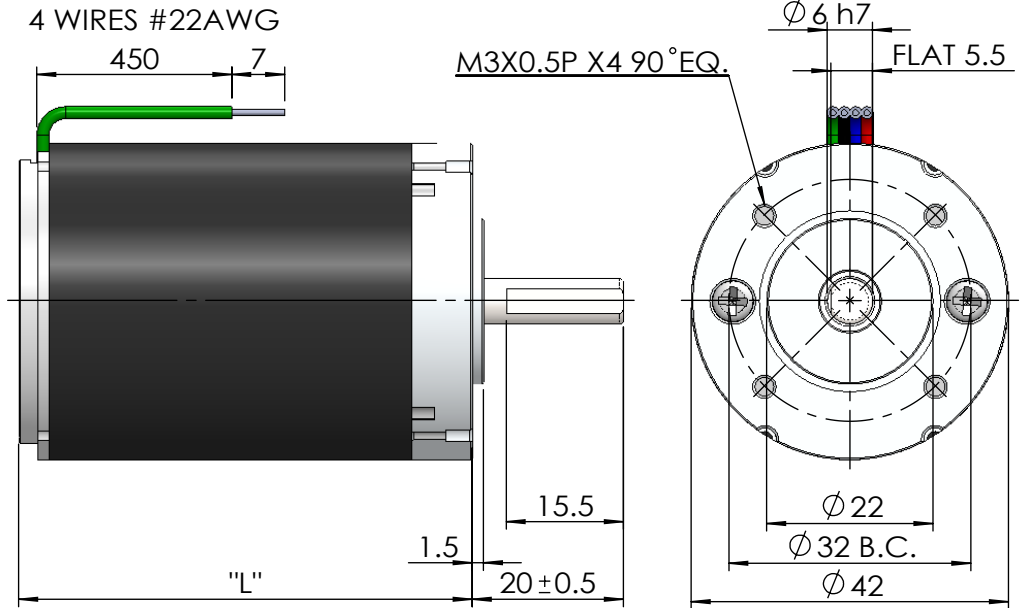

ITEM	PARAMETER	SYMBOLS	UNITS	RE42S	RE42M	RE42L
1	Voltage	V _r	V D.C.	24	24	24
2	No load speed	N _o	R.P.M.	5300	5200	4800
3	No load current	I _o	mA	130	140	250
4	Rated speed at max. efficiency	N _r	R.P.M.	4423	4619	4172
5	Rated current at max. efficiency	I _r	mA	754	1186	1723
6	Rated torque at max. efficiency	T _r	Gr-Cm	273	447	720
7	Rated power at max. efficiency	P _r	W	12.4	21.2	30.8
8	Efficiency	η	%	68.6	74.5	74.6
9	Stall torque	T _s	Gr-Cm	1650	4000	5500
10	Stall current	I _s	mA	3900	9500	11500
11	Peak output power	P _{max}	Watts	22.5	53.4	67.8
12	Terminal resistance	R _t	Ohms	6.15	2.53	2.09

E Series *Integrated Easy Use Driver*

Item	Pin No.	Color of Wire	Symbol	Input or Output	Function	Standard Condition
I/O	1	Red	VM	Input	Power supply positive for drive (Enable)	DC12V~24V MAX. (voltage speed control)
	2	Blue	Brake	Input	Brake operates	Connect to GND
	3	Black	GND	-	Power supply GND	
	4	Green	F/R	Input	H: CCW L: CW	H: GND open L: connect to GND

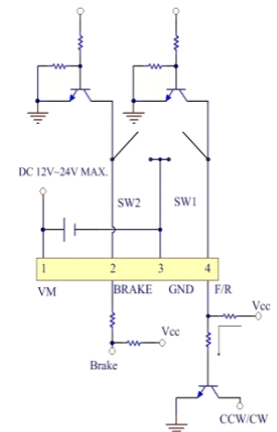

Note: The wire connection on positive and GND is not reversible, otherwise it will cause the motor damaged.

4 LINES